

Approved Gail Farber  
Gail Farber

Approved Gary Hildebrand  
for Diego Cadena

Approved Patrick V. DeChellis 6-13-2011  
Patrick V. DeChellis

June 9, 2011

TO Gail Farber

FROM Gary Hildebrand, Cochair *GH*  
Technical Review Committee  
Watershed Management Division

Sree Kumar, Cochair *SK*  
Technical Review Committee  
Design Division

## **GREEN INFRASTRUCTURE GUIDELINES**

### Recommendation

Approve the attached Green Infrastructure Guidelines (Guidelines) for new construction and reconstruction of road and flood projects.

### Discussion

As part of the Board of Supervisors' (Board) motion on February 2, 2011 (A-Memo 3537), the Board asked the Department of Public Works to report back on the progress made incorporating low-impact development (LID) principles into the Department's Road and Flood Design Practices. Watershed Management Division chaired the LID Committee, which involved participation from several divisions to develop the attached Guidelines. The Technical Review Committee has reviewed the Guidelines and is now forwarding them for approval

*BH*

Gail Farber  
June 9, 2011  
Page 2

The Guidelines provide LID design options to consider during planning or designing of road and flood projects. The Guidelines identify parameters to consider during design and anticipated maintenance needs. In addition, the Guidelines provide examples of desirable sustainable practices that can be considered for Public Works projects.

**TM:sw**

P:\wmpub\Secretarial\2011 Documents\Memos\Approval LID Guidelines.doc\C11110

**Attach**

**cc: Architectural Engineering  
Construction  
Design  
Environmental Programs  
Flood Maintenance  
Geotechnical and Materials Engineering  
Land Development  
Programs Development  
Road Maintenance  
Water Resources**



# ***Green Infrastructure Guidelines***



## ***Low Impact Development and Other Sustainable Practices For Public Works Projects***

Prepared by:  
County of Los Angeles  
Department of Public Works  
June 2011

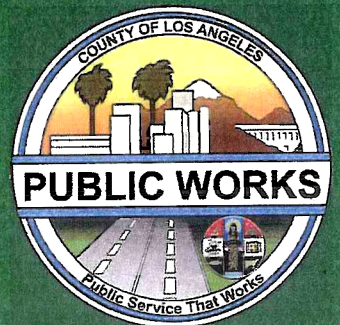





## **TABLE OF CONTENTS**

<b>Chapter 1:</b>	<b>Introduction</b>	<b>Page 1</b>
<b>Chapter 2:</b>	<b>Design Requirements</b>	<b>Page 3</b>
<b>Chapter 3:</b>	<b>Best Management Practices</b>	<b>Page 5</b>
	<i>Permeable Surfaces</i>	<b>Page 5</b>
	<i>Vegetated BMPs and Landscaping</i>	<b>Page 9</b>
	<i>Stormwater Conservation Facilities</i>	<b>Page 18</b>
<b>Chapter 4:</b>	<b>Sustainable Pavement Alternatives</b>	<b>Page 28</b>
<b>Chapter 5:</b>	<b>Sustainable and Green Practices Alternatives</b>	<b>Page 37</b>



**THIS PAGE IS INTENTIONALLY LEFT BLANK**

# **CHAPTER 1: INTRODUCTION**

## **PURPOSE OF THIS DOCUMENT**

In 2008, the County Board of Supervisors (Board) adopted three green ordinances (Green Building, Drought-Tolerant Landscaping, and Low-Impact Development [LID]) that require developers to implement sustainable practices in their projects to protect natural resources within the County of Los Angeles (County). The Board also requested that the County of Los Angeles Department of Public Works (Public Works) establish Green Infrastructure Guidelines (Guidelines) for its own infrastructure projects. The purpose of these Guidelines is to provide options to incorporate LID concepts and other sustainable practices into the design, construction, and operation of Public Works' infrastructure.

Green practices minimize the overall impact to the environment by implementing the principles of LID and sustainability. Incorporating green practices to Public Works' operations can be cost-effective and conserve natural resources such as water and energy. In addition to conservation, green practices also address issues such as air and noise pollution as well as other environmental impacts. Green practices can be integrated in planning and design processes to lessen future economic, social, and environmental impacts of development.

## **LID**

Urban runoff pollution is a significant environmental concern for the County. Conventional drainage infrastructure systems that accompany development typically inhibit natural hydrologic functions by creating large impervious surfaces that prevent infiltration and groundwater recharge and increase runoff that results in discharge of polluted runoff to streams, rivers, lakes, and the ocean. LID practices can help mitigate the impacts of urbanization due to stormwater runoff.

One element of LID is to manage rainfall runoff at its source using Best Management Practices (BMPs). The goal of LID practices is to mimic a site's undeveloped hydrology by using design practices and techniques that capture, filter, store, evaporate, detain, and/or infiltrate runoff close to its source.

LID offers a wide range of benefits that include reducing runoff, preventing river and ocean pollution, reducing potable water use, recharging groundwater aquifers, and providing additional open space. The Guidelines suggest design alternatives that can be implemented within existing and newly developed road and flood infrastructure projects.

## **SUSTAINABILITY**

The County General Plan defines sustainability as a concept that involves the utilization of planning practices that ensure people's needs in the present are met without compromising the ability of future generations to meet their economic, social, and

environmental needs. Public Works is committed to implementing practices and promoting policies consistent with the principles of sustainability while accomplishing its mission of “enhancing our communities through responsive and effective public works services ”

Along with LID, the principles of sustainability through the use of green practices also serve to mitigate the overall impacts of development and urbanization. Implementing the concepts of LID and green practices will enable the County’s infrastructure to function with efficiency and durability while keeping its impact on the environment at a minimum.

## **HOW TO USE THIS DOCUMENT**

Chapter 2 of these Guidelines establishes Green Infrastructure design requirements and applicability for Public Works’ infrastructure projects. Chapter 3 lists various Green Infrastructure design options, the parameters to consider during design and anticipated maintenance needs. Designers may use one or more of the Chapter 3 methods or pursue alternative methods not yet in this manual to achieve the requirements in Chapter 2. Infrastructure design alternatives have been presented in Chapter 3 in three LID-type BMP categories: permeable surfaces, vegetated BMPs and landscaping, and stormwater conservation facilities. Chapter 4 discusses sustainable practices that can be used in pavement alternatives. Chapter 5 contains sustainable and green practice alternatives that can be incorporated into Public Works’ existing operations and practices when applicable. Flexibility can be exercised in implementing the proposed design options considering the critical functions of the infrastructure such as debris basins, reservoir cleanouts, spreading grounds, etc.

## CHAPTER 2: DESIGN REQUIREMENTS

### DESIGN OBJECTIVES

The Standard Urban Stormwater Mitigation Plan (SUSMP) was developed as part of the requirements under the County's 2001 Municipal Stormwater Permit. The SUSMP defines the postconstruction BMP requirements for new and redevelopment projects that infiltrate, capture and/or reuse, or treat all of the runoff from a site during an 85th percentile storm, or 3/4-inch rainfall in a 24-hour period (SUSMP design storm)

These Guidelines intend to set postconstruction runoff mitigation requirements that are on the same order of magnitude as the ones in SUSMP. As the first step, these Guidelines have established a minimum runoff mitigation policy that requires at least 30 percent of the SUSMP design storm runoff volume to be mitigated for all County road and flood infrastructure projects. Designers should pursue greater volume mitigation at project sites where it is practical. It should be noted that the postconstruction BMP requirements may be revised based on the provisions in future National Pollutant Discharge Elimination System (NPDES) municipal stormwater permits.

### APPLICABILITY

For the purposes of this document, project area is defined as the boundary of proposed improvements (construction/reconstruction) within Public Works' right of way. For new median construction/reconstruction projects, the project boundary would be limited to the area that is being reconstructed. New pervious areas within the project area such as open space, medians, and parkway can be used as credit toward the minimum 30 percent volume reduction. Project areas are not expected to accommodate offsite tributary runoff.

Table 1 indicates activities that must conform to or are exempt from Guidelines.

In addition, technical infeasibility criteria for on-site retention and storage/reuse found in *County of Los Angeles for LID Standards Manual (2009)* are also applicable to these Guidelines.

Any developer or other independent party shall meet the requirements of these Guidelines for each project or portion thereof that are within public right of way, consistent with the specific requirements included in Table 1.



TABLE 1 – Activities subject to Green Infrastructure Guidelines

Activities that <b>MUST CONFORM</b> to the Guidelines	Activities that are <b>EXEMPT</b> from the Guidelines
<p>All LACDPW Road and Flood new construction and reconstruction projects within Public Right-of-Way that create or affect an impervious project area of greater than 5,000 square feet.</p> <ul style="list-style-type: none"> <li>• Road project examples include <i>New and reconstruction of public roads, maintenance access roads, road widening, medians, bike paths, sidewalks, parking lots, grade separation, etc.</i></li> <li>• Flood project examples include <i>New concrete flood control channels, new concrete storm water and debris detention facilities, new pump stations, etc.</i></li> </ul> <p>Any work done within Public Works Right-of-Way by developers, private parties, or any other jurisdiction other than LACDPW shall also comply with the above requirement.</p>	<p>Any LACDPW maintenance and repair projects</p> <ul style="list-style-type: none"> <li>• Road project examples include <i>Road resurfacing, chip seal, slurry seal, minor shoulder paving, overlays, etc</i></li> <li>• Flood project examples include <i>Maintenance and repair projects of existing flood control channels, storm drains, debris basins, dams, spreading grounds, sediment placement sites, access roads, pump stations etc.</i></li> </ul> <p>Any Project that is governed by the LA County “Low Impact Development” (LID) Ordinance for Development, see Title 12 Chapter 12 84</p>

**NOTE.** In the event an LID feature cannot be incorporated in the project, documentation shall be included in the project file specifying the type of LID feature that was considered and reasons why it cannot be incorporated

Although some projects are exempt from these guidelines, the engineer/planner is encouraged to consider LID features where the conditions are favorable

# CHAPTER 3: BEST MANAGEMENT PRACTICES

## PERMEABLE SURFACES

### GOAL

The goal of maximizing the use of permeable surfaces is to reduce the total volume of runoff and peak-runoff flow, replenish groundwater, and improve water quality

### EXPLANATION

Conventional concrete and asphalt are impervious surfaces that prevent infiltration of rainfall. During a storm event, runoff from impervious surfaces can carry a high level of pollutants, which are transported to the drainage system into the nearest water body such as a stream, lake, or the ocean. Permeable surfaces and permeable pavement incorporate subbase of uniformly graded aggregate to store runoff and allow natural infiltration to occur resulting in groundwater replenishment, runoff reduction, and water quality improvement.

### DESIGN ALTERNATIVES

#### 1. PERMEABLE SURFACE APPLICATIONS

##### A. Design Parameters for all permeable surface applications

1. The soil-percolation rate must be determined as per procedures prepared by Geotechnical and Materials Engineering Division (GMED) before permeable surfaces are proposed. Soils with lower percolation rates require additional subbase to prevent ponding on the surface of the pavement with the minimum percolation rate for soil being 0.5 inch per hour
2. Aggregate should be uniformly graded, clean washed, and contain 40 percent void space. Aggregate shall also conform to all applicable American Association of State Highway and Transportation Officials standards.
3. Permeable surfaces shall have a grade of less than 5 percent to ensure adequate infiltration
4. Sufficient subbase and overflow shall be provided to accommodate subsurface water movement. The underdrain shall be designed and located according to the *County of Los Angeles Department of Public Works BMP Design and Maintenance Manual (Public Works BMP Design and Maintenance Manual)*, page 3-8

- 5 Pretreatment of runoff, such as use of filter strips or vegetated swales, should be provided in available areas where placement of these BMPs is appropriate for their use. This prevents clogging of the void spaces within the permeable surfaces.
- 6 Permeable pavement, sidewalk, and curb/gutter applications must conform to all applicable American Society of Testing and Materials Standards
- 7 Overflow drains shall not run onto permeable pavement surfaces.
- 8 Areas with little or no vehicular traffic volume or load are recommended. Pressure from heavy vehicles can greatly impact the durability of permeable surfaces.
- 9 When planting street trees that overhang permeable surfaces, select trees with minimum litter, fine debris, and/or tree sap and provide large tree wells. In addition, avoid placement of permeable surfaces near trees that produce litter or fine debris.
- 10 Avoid compaction due to construction equipment and foot traffic on infiltration areas prior to installation. Keep construction equipment off permeable surfaces during construction to avoid compaction.
- 11 NPDES permits specify that the water table depth should be 10 feet or more to protect groundwater quality. In areas with high groundwater tables, regulations may dictate the quality and quantity of water infiltrated.
- 12 Utility locations must be verified. Specific depths and setbacks from utility companies must be addressed.
- 13 Avoid infiltration to existing sewer lines by encasing or lining the sewer system.
14. Provide an impermeable membrane or an underdrain system to prevent saturation when necessary such as sites with contaminated soil or landfills.

B Applications of Permeable Surfaces

1 Permeable Sidewalks

Permeable sidewalks must adhere to existing Public Works standards for sidewalk design.

- 2 Permeable Access Roads Not recommended for roadways with a high volume of equipment trucks. Heavy vehicles can cause damage to permeable surfaces
- 3 Exclusive Bike Paths (Single-Purpose, Nonvehicular Path)
  - a Ensure that contributing and adjacent area is stabilized to avoid sediments.
  - b Must adhere to existing Public Works standards for bike path design
- 4 Permeable Parking Lots

Permeable pavement and underdrain systems shall be directed toward LID-type BMPs if needed to achieve the required volume reduction
- 5 Permeable Alleys

Recommended for narrow alleys less than 8 feet wide since they prevent access from heavy vehicles The portion of the alley adjacent to structures are to be subject to compliance with building codes.
- 6 Permeable Street Gutters

Avoid areas subject to lateral loading, such as street corners and driveways
- 7 Permeable Material on Reinforced Concrete Box (RCB) Storm Drains Although underground storm drains do not affect impervious surface areas, LID features may be optionally considered
  - a Permeable material may be used on the invert of the storm drain as long as the structural integrity of the RCB is maintained
  - b Perforation filled with permeable materials along the invert.
  - c Permeable scour protection at the downstream end of the outlet.
  - d Structural integrity of the storm drain must be evaluated
  - e The segment of permeable surfaces shall be restricted to 1/3 of the RCB width



- f Use of permeable material shall have no significant impact to the capacity of the system
  - g Consider only RCB higher than 4 feet 9 inches.
  - h Pretreatment of inflows may be needed where access for maintenance is limited
  - i Check with Design (DES) Division to establish maximum flow velocity to limit scouring of the invert.
- 8 Engineered Perforated Bank Protection and Permeable Material Use in Concrete Channel
- a Permeable material within a concrete channel could be considered for short reaches provided the structural integrity of the channel is not compromised
  - b The use of permeable material may not significantly impact the flood control system capacity
  - c. May need additional permits for activities within the waterway from permitting agencies
- C Maintenance Requirements for all Permeable Surface Applications
- 1 Continued maintenance, such as vacuuming, blowing, or sweeping, ensures continued performance of the surface over its lifetime. The permeable surface must be vacuumed a minimum of once after every storm season, but it is recommended to be vacuumed ***four times a year*** with a commercial cleaning unit to keep the system clean throughout the year and prolong its life span.
  - 2 Maintain well-draining and litter-free planted areas adjacent to permeable surfaces to prevent sedimentation of porous surfaces.
  - 3 ***Monthly*** inspection to ensure that permeable surfaces are free of sediment.
  - 4 Do not allow construction staging, soil, or mulch storage, etc., on unprotected permeable surfaces. This will limit the use of permeable surface on facilities such as debris basin or sediment placement sites
  - 5 Upon failure, permeable surfaces require rehabilitation.

- 6 Underground stormdrains shall not be subject to the previous maintenance requirements. They shall be inspected under the current inspection routine schedule.

## **VEGETATED BMPs AND LANDSCAPING**

### **GOAL**

The goal of implementing vegetated stormwater management elements, such as vegetated swales, bioretention, and filter strips, is to maximize permeable space and evapotranspiration, reduce runoff pollutant concentrations, and reduce peak-runoff rates.

### **EXPLANATION**

The following LID-design alternatives will enhance and improve our environment by replicating the natural hydrology process by using landscaping and/or vegetation to treat stormwater. Design elements, such as tree planting and preservation of existing trees, maximizes landscape and vegetation areas and increases the exchange of water and air at soil surface, improves air quality, and enhances the aesthetic value of our communities. Maximizing tree plantings and preserving existing trees will also reduce the heat island effect, retain water through foliage and roots, increase wildlife habitat, and improve real estate values. The vegetation policies will be subject to the pending Army Corps Levee vegetation policies.

The LID practices introduced herein involve two distinct unit processes: biofiltration and bioretention. Each unit process has a unique purpose and its own set of design parameters and constraints that apply to all facilities utilizing that specific unit process. Biofiltration reduces pollutant loads in runoff through a combination of vegetation with slow and shallow flow. The treated water then flows into either another LID facility utilizing an infiltration unit process or into a flood control conveyance. Bioretention utilizes vegetation as well as an engineered soil mixture that filters pollutants out of the water before infiltration into natural soil. This chapter will address the specific design parameters and constraints for each unit process and how these constraints are applied to the specific LID elements. Tree planting and preservation of existing trees also serve as natural LID elements that naturally provide biofiltration and bioretention prior to infiltration.

### **DESIGN ALTERNATIVES**

The following apply to all items presented in this chapter:

- Utility locations must be verified. Depth and specific setback requirements from utility companies must be addressed.
- Topography of each specific site must be studied to determine the feasibility of implementing LID elements.

- Plant selection
  - Vegetation to be determined by landscape architect, biologist, or botanist.
  - Plants shall be selected for their ability to tolerate pollutants and extreme wet and dry conditions
  - All plants shall be noninvasive species
  - Diversify plant species to minimize massive single species die back.
  - Plants shall be low maintenance

Biofiltration (Includes Vegetated Swales, Vegetated Buffers, and Planter/Tree Box Filters)

- Biofiltration is typically referred to as pretreatment used in conjunction with other LID practices that utilize an infiltration unit process. Biofiltration facilities are also used to pretreat runoff before discharge to flood control infrastructure.
- Steep terrain and/or large tributary area may cause concentrated, erosive flows. It is not recommended for facilities such as a sediment placement site.
- Flat sites with a limited site slope may result in ponding
- Soils shall be amended with 2 inches of well-rotted compost unless the organic content is already greater than 10 percent. The compost shall be mixed into the native soils to a depth of 6 inches to prevent soil layering and washout compost.

Bioretention.

- Bioretention utilizes vegetation and soil that filter pollutants out of the water prior to infiltration into native soil.
- Soil percolation rate must be determined as per procedures prepared by GMED. An underdrain system is required for soils with low-percolation rates (less than 0.5 inch per hour) to allow flow to an existing storm drain.
- Avoid infiltration to existing sewer lines by encasing or lining them to the sewer system

- Pretreatment using biofiltration is required for bioretention facilities that are designed to treat and infiltrate runoff from roadways
- Bioretention facilities may not be located within industrial areas or within 100 feet of a drinking-water well
- Soil and planting media shall conform to Chapter 5 of the *Public Works BMP Design and Maintenance Manual*.

## 1. VEGETATED SWALES

- A. Design Parameters for All Road and Flood Right-of-Way Projects
- 1 Vegetated swales shall be designed per Chapter 3 of the *BMP Design and Maintenance Manual*
  - 2 Outlet must have the capacity to handle overflows from a 50-year capital storm.
  - 3 Flow capacity of vegetated swales should be such that the design water-quality flow rate will not exceed a flow depth of 2/3 the height of vegetation within the swale or 4 inches at the SUSMP design intensity (page 3-2 of the *BMP Design and Maintenance Manual*)
  - 4 Vegetated swales are impractical in areas with steep topography (slopes exceeding 10 percent such as debris basins or sediment placement sites) Recommended slope is between 1 and 6 percent
  - 5 If longitudinal slope (in direction of flow) exceeds 6 percent, provide flow-control devices, such as check dams to decrease flow velocity
  - 6 If longitudinal slope is less than 15 percent and the soils are poorly draining, then underdrains shall be provided as described in Chapter 3 of the *BMP Design and Maintenance Manual*
  - 7 Select plant species that are tolerant to both extreme wet (maximum one to two days submerged) and dry conditions Native and Mediterranean climate plants are usually adapted for this application Plants shall also have some capability to uptake water-soluble pollutants in stormwater (refer to vegetated swale plant list on page 3-9 of the *BMP Design and Maintenance Manual*)
  - 8 Provide permanent irrigation system for dry-weather conditions, although drought-tolerant grasses should be specified to minimize irrigation requirements



- 9 Swale length should be greater than 100 linear feet and the overall depth from the top of the sidewalks to the swale bottom shall be at least 12 inches

B Design Parameters for Median/Service Islands

- 1 Require all medians to be set below grade to accommodate future roadway geometry modifications.
- 2 Use of check dams may be hazardous to out-of-control vehicles that end up in the median or shoulder area. Applications of check dam shall require DES and Traffic and Lighting (T&L) Divisions approval.
- 3 Minimum width of median required – 4 feet (face-to-face)
- 4 Provide curb cut if adjacent roadway surface drains toward median
- 5 Provide hydrology calculation to determine curb cut size and distance between curb cuts. Curb cuts shall be placed slightly above the elevation of the vegetated areas. Curb cuts should be at least 12 inches wide to prevent clogging
- 6 Provide an impermeable membrane between the roadway and swale or an underdrain system to prevent saturation underneath the roadway
- 7 Sight distance - Refer to the *Typical Landscape Design Standard* by T&L for sight distance and plant height requirements and check with T&L for site-specific requirements.
- 8 Retrofit of an existing roadway (for road reconstruction projects only)
- 9 Minimum length of reconstructed segment required – 1,000 linear feet (along centerline)
- 10 Minimum slope of inside lane (lane number 1) toward the median - 1.8 to 2 percent range
- 11 Transition to be away from intersections (to avoid dips for opposing streets)

C Design Parameters for Parkways (Road Right of Way)

- 1 Minimum width of right of way required – 8 feet (4-foot sidewalk plus 6-inch curb on street side, plus 6-inch curb on sidewalk side, plus 3-foot swale width)

2. Minimum distance between curb face and edge of swale shall be 30 inches, otherwise, post “No Parking” or “No Stopping” signs and check with T&L for site-specific requirements
  3. Adjacent parking situation shall be reviewed by T&L
  4. Where street trees exist (or are proposed), root balls are to be separated from the swale
- D Design Parameters for River and Channel Greenway Projects (Los Angeles County Flood Control District ([LACFCD]) right of way)
1. All designs within the Los Angeles River Watershed shall comply with the *Los Angeles River Master Plan Landscaping Guidelines and Plant Palettes* (January 2004) Check with Architectural Engineering Division (AED) for other watersheds.
  2. Plant species within the Los Angeles River Watershed shall comply with the *Los Angeles River Master Plan Landscaping Guidelines and Plant Palettes* (January 2004) Check with AED for other watersheds.
  3. Minimum distance between edge of proposed swale and channel wall is 12 feet.

## 2. VEGETATED BUFFERS

### Design Parameters for Roadside Shoulders

- Vegetated buffers shall be designed per Chapter 4, Filter Strips, of the *BMP Design and Maintenance Manual*
- Vegetated surfaces should treat sheet flow from adjacent, gently sloping, impervious surfaces. The lateral slope of the contributing area should be 4 percent or less. The longitudinal slope of the contributing area should be 5 percent or less
- Seasonal high groundwater levels should be at least 2 feet lower than the strip surface to ensure that the filter strip dries between storms
- Slope shall be between 2 and 5 percent in the direction of flow to create uniform sheet flow
- The top of the strip should be installed 2 to 5 inches below the adjacent pavement to allow sediment and other pollutants to settle. Avoid on roads with high vehicle volume since drivers may lose control of the vehicle due to drop off

- Minimum length (in direction of flow) required is 4 feet
- Strip shall be free of gullies or rills

### 3. BIORETENTION

#### A. Design Parameters for all Projects within Road or Flood Right of Way

- 1 Bioretention facilities shall be designed per Chapter 5, Bioretention, of the *Public Works BMP Design and Maintenance Manual*
- 2 Minimum width required is 12 feet
- 3 Site must have adequate relief between land surface and storm drain to permit vertical percolation through the soil media, collection, and conveyance through underdrain to storm drain system
- 4 Maximum allowable drain time should not exceed 48 hours
- 5 Energy dissipation practices shall be incorporated in bioretention areas, such as the use of ungrouted rocks and other erosion protection material in the channel entrance to dissipate energy
- 6 Bioretention area shall be covered with 2 to 4 inches (average 3 inches) of mulch at the start and an annual placement of 1 to 2 inches of mulch beneath plants
- 7 Overflow device is required at the 18-inch ponding depth (refer to page 5-7 of the *BMP Design and Maintenance Manual* for overflow design)

#### B. Design Parameters for Bulb-Out Design being used for LID within Road Right of Way

- 1 Bulb-outs shall be designed per Chapter 5 of the *BMP Design and Maintenance Manual*
2. Bulb-outs shall be on residential streets and near an existing storm drain or catch basin
- 3 Bulb-outs shall be staggered along the residential street to provide room for the drivers. At least 24 feet driving width shall be available at all times
- 4 At least 30 feet from intersections unless the bulb-out includes/ extends to the intersection return

- 5 Maximum width – 8 feet or typical width of the parking area
- 6 Open gutter between the standard parkway curb and the bulb-out is not recommended for locations where sidewalk is adjacent to the curb
- 7 Shrubs in bulb-out areas should be a maximum of 3 feet high to maintain sight distance for driveways.
- 8 Consult with T&L, Traffic Investigations Section, if there are objections to eliminating parking by providing a sketch of the proposed bulb-out locations.
- 9 All cases shall be individually reviewed by T&L

**4. PLANTING/TREE BOX FILTER – Parkway (Road Right of Way)**

Planting/tree box filters may require pretreatment and adherence to groundwater depth constraints depending upon whether an infiltration unit process is used or not.

**A. Design Parameters**

- Typical planting/tree box filter design includes a concrete vault filled with a bioretention soil mix and vegetation, and may contain an underdrain connected to an adjacent flood control conveyance
- Planting/tree box filter can include an infiltration process if soil conditions, groundwater depth, and vehicle traffic constraints permit. This type of design does not require an underdrain
- Filter media shall be at least 3 feet deep and composed of 80 percent sand and 20 percent compost.
- Provide tree well covers that comply with the Americans with Disabilities Act.
- Select plant species that are tolerant to both extreme wet (maximum one to two days submersion under water) and dry conditions. Native and Mediterranean climate plants are usually adapted for this application. Plants shall also have some capability to uptake water soluble pollutants in stormwater (refer to vegetated swale plant lists)
- Provide permanent irrigation systems for dry-weather conditions
- Allow for 4 to 6 inches of ponding



## 5. TREE PLANTING

### A. Design Parameters

- 1 Plant trees for all new projects within road and flood right of way  
This only applies to right of way where the LACFCD has a fee title
- 2 Refer to T&L's *Typical Landscape Design Standards* regarding sight distance and minimum setback requirements for tree plantings within road medians and service islands
- 3 For tree planting within road right-of-way median/service islands and parkway in urban areas
  - a Refer to Master Parkway/Median Tree List by Road Maintenance Division (RMD) for approved tree list.
  - b Refer to *Standard Plans for Public Works Construction 519-2* for other requirements.
  - c. Submit tree planting plan for traffic safety review and approval by T&L
  - d Trees shall not obstruct traffic signs or traffic signal heads.
4. Refer to *Roadside Design Guidelines* recommendations by DES and T&L for tree planting within road right of way in rural areas
- 5 For projects within the Los Angeles River, refer to the *Los Angeles River Master Plan Landscaping Guidelines and Plant Palettes* (January 2004) regarding approved tree species and minimum setback requirements for tree planting within LACFCD right of way  
For other watersheds, check with AED
- 6 Provide permanent automatic irrigation systems for all tree planting projects in the RMD, District 5, area due to the particularly harsh climate of Acton, Santa Clarita, and the Antelope Valley
- 7 Add root barriers as needed to prevent uplift and other damage in adjacent roads

### B Maintenance Needs

Refer to RMD's *Tree Maintenance Requirements* (Refer to Chapter 6, Other Green Practices, for mulching recommendations)

## 6. PRESERVATION OF EXISTING TREES

### Design Parameters

- Protect all existing trees where possible unless removal of the trees is unavoidable, is necessary for public safety, or are of exotic weed species.
- Where roots of existing trees are causing damages to existing facilities, such as roadways, sidewalks, and channel walls, preservation of the trees must be attempted by methods such as root pruning, installation of root barriers, or tree trimming during repair of the damaged facility. Consult an arborist for mitigation/preservation recommendations.
- Remove oak saplings less than 3 inches diameter breast height that may impact adjacent facilities.
- Where right of way allows, reroute sidewalks to avoid damaging tree roots
- Where right of way is limited, contact adjacent property owner for possible dedication of right of way to reroute sidewalk away from the tree
- Consider the use of modular rubber sidewalk near existing trees
- During new construction where trees exist, protect the trees by:
  - Fencing within the drip line of the trees to avoid soil compaction and damage to trunks and branches.
  - Depending on the type of tree, the root system may extend beyond the drip line. Consult an arborist prior to construction
  - Water trees during construction per arborist's recommendations

## 7. MAINTENANCE REQUIREMENTS FOR VEGETATED BMPS AND LANDSCAPING

### A. Landscape maintenance requirements

- 1 Trash removal.
- 2 Irrigation inspection

- 3 Plant maintenance (fertilizer, pest control)
- 4 Occasional pruning
- 5 Plant replacement (allow approximately 5 percent replacement per year)
- B Water-quality monitoring to determine effectiveness of BMPs and possible need for maintenance
- C Clean out underdrains when needed to alleviate ponding
- D Provide periodic agronomic soil tests and soil contamination tests
- E Periodic soil maintenance may be required, including possible soil replacement based on the results of soil and contamination tests
- F Soil maintenance (5- to 10-year interval)
  - 1 Accumulated sediment and debris removal
  - 2 Soil replacement and erosion repair

## **STORMWATER CONSERVATION FACILITIES**

### **GOAL**

The goal of implementing stormwater conservation facilities such as retention basins and bioretention areas is to reduce stormwater runoff volumes, runoff flow, and downstream channel erosion as well as improving water quality

### **EXPLANATION**

Stormwater conservation facilities increase the capability to retain and infiltrate runoff within or adjacent to road and flood projects. These facilities can conserve stormwater by capturing it in the flood or road infrastructure where facilities previously did not exist. Water conservation BMPs are typically installed within the stream corridor or upland areas to capture and treat stormwater runoff before it is delivered to receiving waters. They can infiltrate stormwater, remove pollutants, promote natural hydrology, and minimize stream channel erosion.

The proposed design alternatives in this chapter involve retrofits within existing wetlands and waterways of perennial or intermittent streams to either increase existing storage capacity or add new storage facilities. Potential environmental impacts

resulting from these practices must be evaluated and jurisdictional permits with environmental mitigation mandates may be required.

## DESIGN ALTERNATIVES

### 1. ADD STORAGE TO EXISTING DETENTION AND RETENTION FACILITIES

#### A. Design Parameters

- 1 Right-of-way acquisition may be required for new facilities
- 2 Add storage to existing retention or detention basins, such as spreading grounds or desilting basins by (Figure A)
  - a Excavating new storage on basin bottom
  - b Raising the height of embankment.
  - c Modify riser elevations and dimensions.
  - d Installing internal design features to improve performance
- 3 Preliminary excavation and soil borings may be necessary in preparing the retrofit's earthwork design and rough grading plan
- 4 If any of the above measures involves or results in an embankment that comes under the jurisdiction of the California Department of Water Resources' Division of Dams, dam safety permits may be needed
- 5 Retrofitting practices may need to consider the following constraints.
  - a Existing utilities running through the facility's bottom
  - b Presence of flood-prone structures present in the floodplain near the facility

#### B. Maintenance Needs

- 1 Continuous maintenance access by vehicles and other construction equipment
- 2 Vector and weed control
- 3 Minor maintenance, structural repair, and restoration
- 4 Erosion control
- 5 As-needed removal of accumulated sediment and annual basin ripping for continuous basin percolation



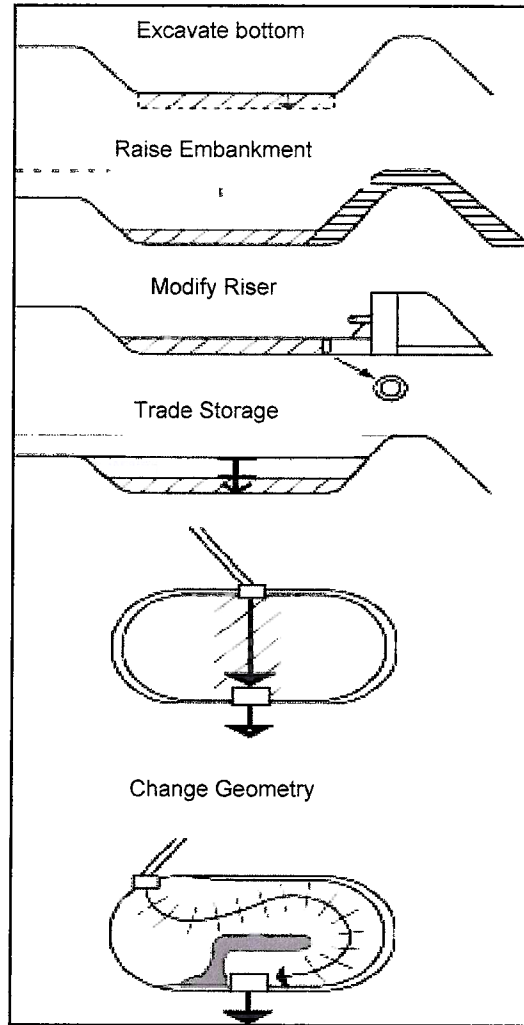

**Figure A: Storage to existing detention and retention facilities (adopted from Urban Stormwater Retrofit Practices, Center for Watershed Protection, 2007)**

## 2. STORAGE ABOVE ROADWAY CROSSINGS

Provide storage immediately upstream of existing and new road culverts that cross low-gradient, nonperennial streams without wetlands. These storage facilities also provide water quality and peak-flow control benefits.

### A. Design Parameters

- 1 New storage can be created by adding wetlands or an extended detention area just upstream of existing and new roadway embankments (Figure B)

- 2 Project storage area may contain sewer lines or other utilities that often run adjacent to streams or parallel to roadways
- 3 Not appropriate for upstream channels that have steep gradients or are deeply incised
- 4 Existing structures that encroach into the floodplain may be subject to a greater flooding risk.
- 5 Retrofitted facilities must retain the facility's original flow capacity

**B Maintenance Needs**

- 1 Agreements that outline maintenance and funding responsibilities may be required depending on which jurisdiction is responsible for the culvert
- 2 Annual inspection and maintenance activities such as minor structural repairs and restoration, unclogging debris, vegetation and sediment from storms and upstream.
- 3 Weed and vector control
- 4 Continuous and safe maintenance and equipment access
- 5 Placement of protective devices such as trash racks and/or oversized forebays or micropools

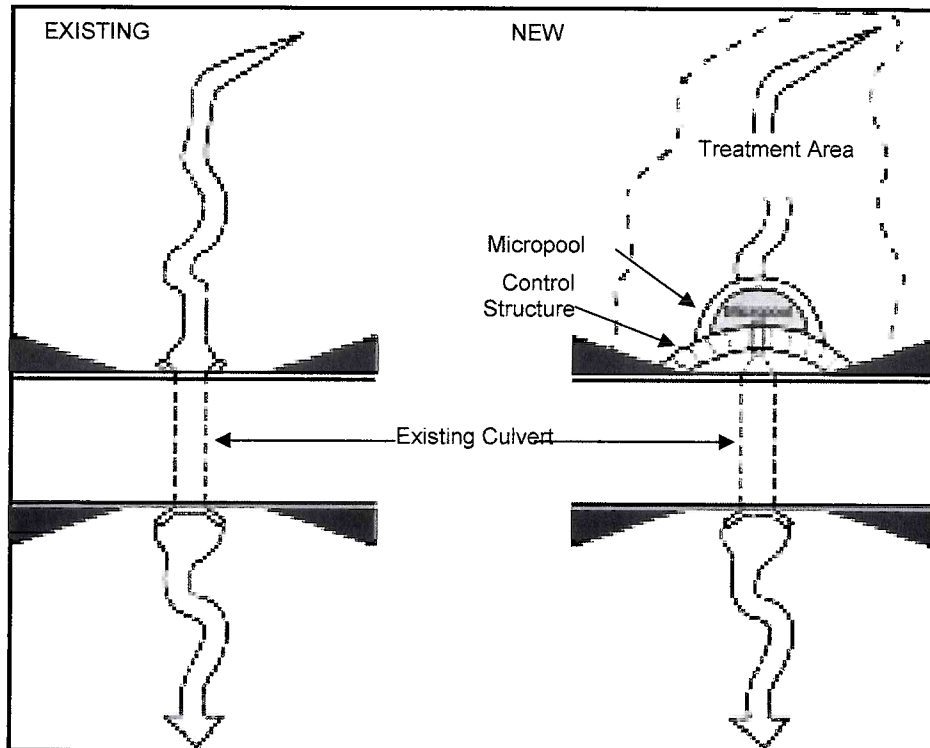

**Figure B: Storage above roadway crossings**  
 (adopted from *Urban Stormwater Retrofit Practices*,  
 Center for Watershed Protection, 2007)

### 3. TREATMENT STORAGE BELOW OUTFALLS

Provide online or offline water-conservation storage just upstream of existing outfalls. Flows can be split from an existing storm drain or channel and diverted to a stormwater conservation area on LACFCD right of way. In addition to water conservation, these facilities can provide water quality and peak-flow reduction benefits.

#### A. Design Parameters

1. Appropriate for storm drain outfalls between 12 to 36 inches that are located near large open spaces such as parks, golf courses, or floodplains (Figure C)
2. Private land adjacent to existing LACFCD right of way may need to be purchased
3. These practices must consider the following constraints.
  - a. Adequate area within or adjacent to the channel or drain

- b Appropriate gradients to prevent high velocities or backwater conditions
- c Hydrologic conditions due to the proposed facility's location, such as tidal influence and storm surges

**B Maintenance Needs**

- 1 Safe, continuous maintenance and equipment access.
- 2 Vector and weed control.
- 3 Annual inspection and maintenance activities such as minor structural repair and rehabilitation of outfall structures.
- 4 Erosion and scour control.

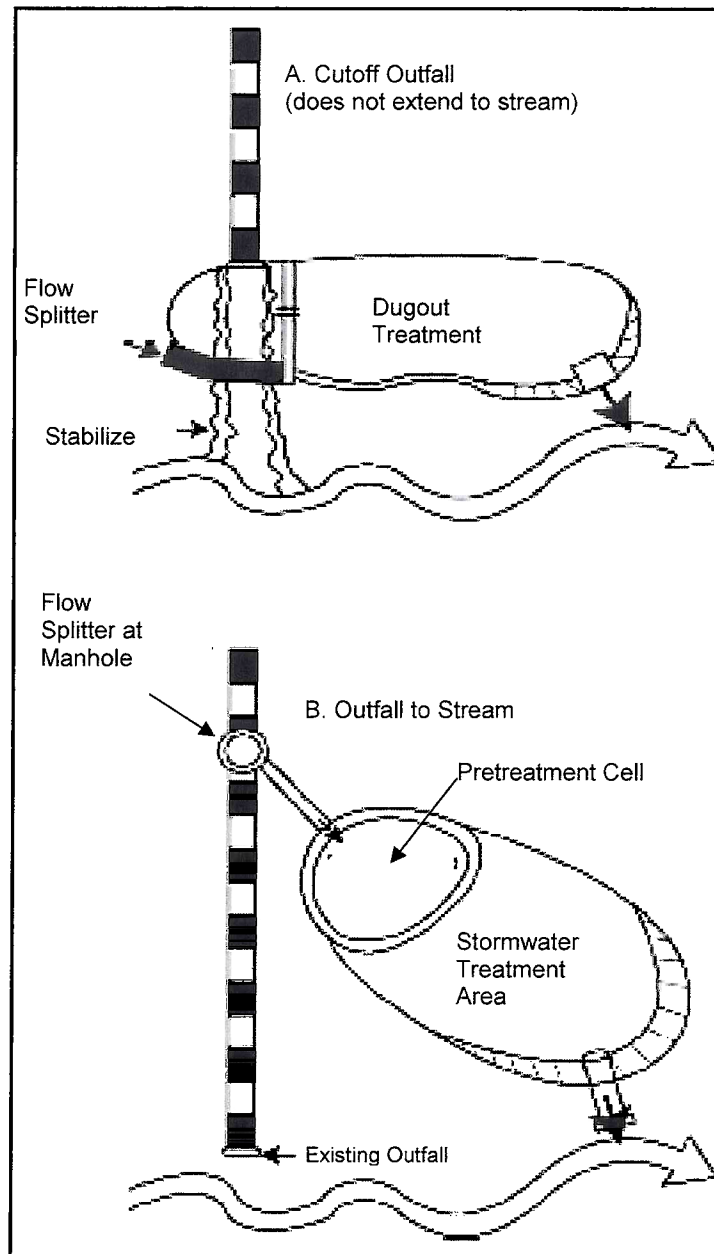

**Figure C: Storage below outfalls**  
 (adopted from *Urban Stormwater Retrofit Practices*,  
 Center for Watershed Protection, 2007)

#### 4. STORAGE IN CONVEYANCE SYSTEM

##### A. Design Parameters

- 1 Add storage in an existing stormwater conveyance system by creating in-line storage cells that filter runoff through swales via small weirs on check dams or by splitting flows within the stream

corridor to off-line storage areas such as constructed wetlands or bioretention areas (Figure D)

- 2 These practices must consider the following constraints
  - a In-line designs are not recommended for streams that are in their natural condition or have adjacent mature forests or wetlands
  - b In-line designs are not recommended for streams that are rapidly degrading/incising or have a knickpoint downstream of the proposed facility
  - c Avoid channels with steep grades and steep side slopes
  - d In-line designs are not recommended for streams with perennial flow
  - e Avoid channels with narrow easement widths, capacities, or adjacent utilities

B. Maintenance Needs

- 1 Weed and vector control
- 2 Storm damage repairs and rehabilitation
- 3 Annual vegetation management activities especially fire-hazard clearing
- 4 Maintenance and equipment access

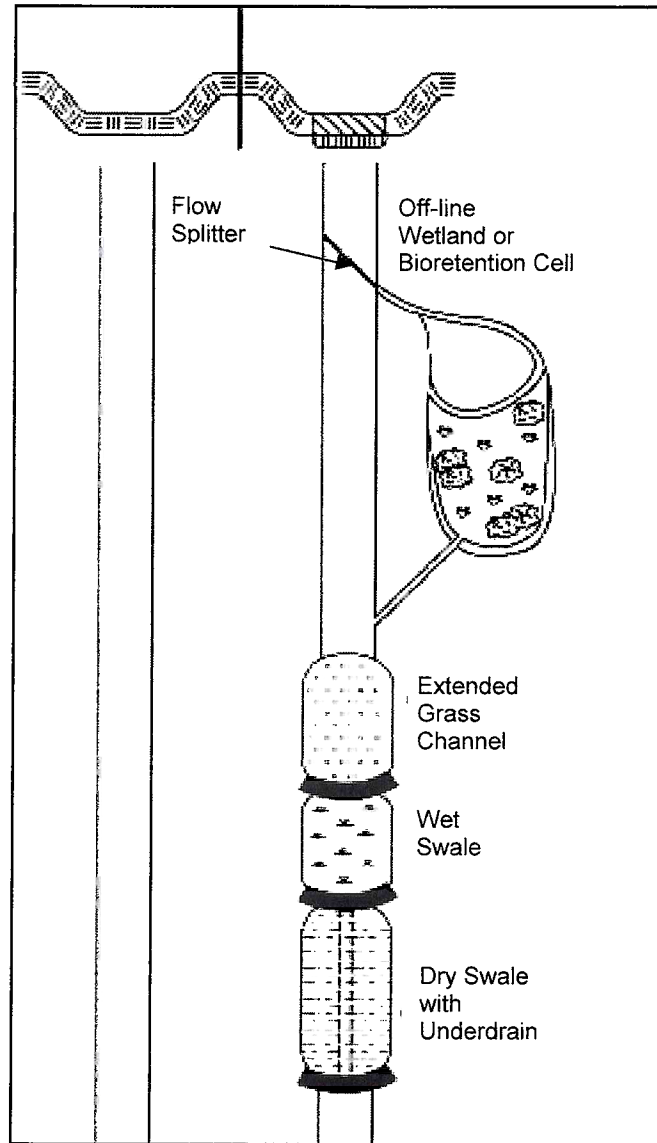

Figure D: Storage conveyance system by in-line or off-line options (adopted from Urban Stormwater Retrofit Practices, Center for Watershed Protection, 2007)

## 5. STORAGE IN ROAD RIGHT OF WAY

Direct road runoff can be stored in a depression or excavated stormwater treatment area within the road right of way and transportation or power line corridors. Prominent examples of storage locations include road cloverleaves, medians, and wide right-of-way areas (Figure E)



A. Design Parameters

- 1 New storage space should not interfere with ongoing road maintenance practices.
- 2 This type of practice may need to consider the following constraints.
  - a Avoid roadways that are likely to be widened or expanded in the future to handle increase traffic flow
  - b Avoid roadways that have guardrails, steep site slopes, or limited sight distance

B Maintenance Needs

- 1 Removal of debris, sediment, litter, and other materials that would otherwise clog the retrofit.
- 2 Dewatering of clogged retrofit.
- 3 Safe and direct maintenance access.
- 4 Compatibility with ongoing road maintenance
- 5 Management of large sediment input from road runoff



Figure E: Storage in road right of way

## **CHAPTER 4: SUSTAINABLE PAVEMENT ALTERNATIVES**

### **GOAL**

Maximize the use of recycled asphalt products (RAP) and reclaimed asphalt products to decrease the disposal of old material, emissions from processing new material, and greenhouse gases from hauling material to and from job sites in support of Public Works' goal of sustainable practices

### **EXPLANATION**

Asphalt is most commonly disposed of by hauling used materials to a designated landfill. In-place recycling practices can be implemented to recycle used asphalt materials. RAP can be used to maintain and restore deteriorated pavements, disrupt reflective cracking, and is cost-effective (up to 50 percent less than traditional mill and fill method). Use of recycled materials conserves natural resources, eliminates 90 percent of construction truck traffic, and can reduce construction working days.

### **DESIGN ALTERNATIVES**

#### **1. COLD-IN-PLACE RECYCLING (CIR) OR CENTRAL PLANT COLD-IN-PLACE RECYCLING (CCPR)**

When asphalt pavement of a road is removed, it is commonly hauled away and disposed of in a designated landfill. Various technologies are available that can recycle or reuse the existing asphalt pavement. In-place recycling processes recycle existing asphalt materials for use in the surface layer of reconstructed roadways. Overall, this practice will reduce greenhouse gases, such as carbon emissions from the processing of virgin material and the hauling of material to and from the job sites, and will reduce the impact to the landfills.

CIR is an on-grade method of pavement rehabilitation that consists of milling a portion of the existing asphalt concrete (AC) pavement or the full depth of the existing AC (4-inch depth) without disturbing the base layer, mixing the cold-milled material with emulsified recycling agent and other additives as needed, spreading and compacting the recycled mixture, and overlaying the recycled surface with a new layer of hot-mix asphalt.

CCPR involves the same process as CIR, except the process is performed at a central or mobile plant facility. This process is used when the base or subgrade material may need to be modified. Both cold recycling methods are used as an asphalt base course.

A. Design Parameters

- 1 For the CIR method, verify that there is sufficient thickness of the AC surfacing in place (4-inch minimum) Also, verify from the subgrade sampling the presence of weak base underlying the pavement.
- 2 The subgrade should not be expansive or yielding from GMED's California Bearing Ratio tests (California Bearing Ratio greater than 20 and expansions less than 5 percent)
- 3 The existing drainage conditions must be sufficient to prevent surface deterioration and softening of the subgrade in order to ensure long-term performance of the pavement after the CIR
- 4 The existing appurtenant structures (e.g , guardrails, handicap curb ramps, bridge clearances) cannot impose limitations on the existing road geometry
- 5 Determine whether pavement fabric is present within any of the structural section layers. Dispose of fabric during construction Place asphalt paving surface over recycled asphalt base course

B Maintenance Needs

After the construction of asphalt pavement surfacing over the CIR/CCPR base, apply preventive maintenance treatment (i e , seal coat) in 3 or 4 years.

**2. HOT-IN-PLACE RECYCLING**

Hot-in-place recycling is an on-grade method of pavement surface preservation that consists of softening the existing asphalt pavement with heat, milling, or scarifying the existing AC to a maximum depth of 2 inches and thoroughly remixing, leveling, and compacting the milled or scarified material Hot-in-place recycling can include the addition of recycled agents and virgin hot-mix asphalt.

A. Design Parameters

- 1 For roadways with light truck traffic.
- 2 Best suited to treat the following pavement distresses and surface irregularities
  - a Raveling
  - b Bleeding

- c. Corrugations
- d Shoving
- a Slippage
- b Poor-ride quality
- c Shallow rutting
- d Shallow potholes
- e Thermal cracking (longitudinal, transverse, map)
- f Reflective cracking

3 Not suited for pavements.

- a Which have multiple chip seals with previous treatments
- b Made with asphalt rubber hot mix.
- c Having a geosynthetic pavement interlayer or fabric.
- d With structural inadequacy
- e Having greater than 5 percent alligator cracking
- f Having moderate to excessive filled cracks
- g Having base or subgrade failure
- h Having moisture related problems including poor drainage, pumping, or saturated subgrade material

#### B Maintenance Needs

There are no specific maintenance needs beyond the normal road maintenance practices

### 3. CIR

CIR is an on-grade method of pavement rehabilitation that consists of milling the existing AC pavement 2 to 4 inches in depth, mixing the cold milled material with emulsified recycling agent and other additives as needed, spreading and compacting the recycled mixture, and overlaying the recycled surface with a new layer of hot-mix asphalt. Foamed asphalt can be used as a recycling agent instead of asphalt emulsion, but fine aggregates may need to be added to the recycled mixture

A. Design Parameters

- 1 Must recycle at least 70 percent of the existing pavement thickness.
- 2 For low to moderate volume roads that are structurally adequate
- 3 Best suited to treat the following pavement distresses and surface irregularities.
  - a Raveling
  - b Weathering
  - c Bleeding
  - d Corrugations
  - e Shoving
  - f Slippage
  - g Poor-ride quality
  - h Rutting
  - i Patches
  - j Shallow potholes
  - k Cracking
- 4 Not suited for pavements.
  - a With high traffic volumes
  - b Made with asphalt rubber hot mix
  - c Having deep cracking
  - d Having a geosynthetic pavement interlayer or fabric
  - e With moisture related problems including poor drainage, pumping, or saturated subgrade material
  - f With numerous utility access points throughout the road
  - g Undergoing nighttime construction work
  - h In urban areas with existing noise pollution

- i In cold or wet weather (minimum pavement temperature is 60 degrees Fahrenheit and minimum ambient temperature is 50 degrees Fahrenheit)

B Maintenance Needs

There are no specific maintenance needs beyond the normal road maintenance practices

**4. FULL-DEPTH RECYCLING**

Full-depth recycling is an on-grade method of pavement rehabilitation that consists of pulverizing the existing AC pavement and a portion of the underlying granular base to a maximum depth of 12 inches, grading and compacting the recycled mixture, and overlaying the recycled surface with a new layer of hot-mix asphalt. Other materials including aggregate base, lime, Portland cement, kiln dust, or fly ash may be added prior to mixing as needed.

Pavement pulverization provides an alternative to conventional rehabilitation methods and can be an economical method of conserving and reusing existing pavement materials. The pulverization process transforms an existing distressed flexible pavement into base for a new flexible pavement structure.

A. Design Parameters

- 1 Must recycle at least 70 percent of the existing pavement thickness.
- 2 For low to moderate volume roads that are structurally adequate
- 3 Can treat most pavement distresses that are not caused by subgrade or drainage problems.
- 4 Effective on surfaces requiring digouts of 20 percent or more by paving area.
- 5 Best suited to treat the following pavement distresses and surface irregularities
  - a. Raveling
  - b. Corrugations
  - c. Slippage
  - d. Shoving
  - e. Bleeding
  - f. Poor-ride quality

- g Rutting
  - h Potholes
  - i Cracking
  - j. Delamination
- 6 During construction, vehicles must traverse an untreated surface (pulverization requires 24-hour pilot car traffic control)
  - 7 Not suited for pavements
    - 1 With high-traffic volumes.
    - 2 In residential neighborhoods (pulverization is noisy)
    - 3 With geosynthetic pavement interlayer
    - 4 With treated bases
    - 5 With numerous shallow utilities
    - 6 With poor drainage

**B Maintenance Needs**

There are no specific maintenance needs beyond the normal road maintenance practices

**5. SOIL CEMENT**

Soil cement is an alternative construction material to concrete that can be used for bank protection, bike trails, access roads, or other pavement surfaces. Soil cement is a mixture of used natural earth and rock materials and enough Portland cement to produce a mix with sufficient strength and plasticity for floor and wall construction. Soil cement is a cheap alternative to the concrete delivered by Redi-Mix trucks, which can be very expensive if the required load is small or delivery time is long.

**A. Design Parameters**

- 1 Must meet County requirements for soil cement standard plan details, construction specifications, and quality control program.
- 2. Scope of Work must be large to use soil cement as an alternative to concrete



## B Maintenance Needs

There are no specific maintenance needs beyond the normal road maintenance practices

## 6. PERPETUAL PAVEMENT

Perpetual pavement is an AC pavement designed and built to last longer than 50 years without requiring major structural rehabilitation or reconstruction, but only needing periodic maintenance to address distresses in the top layer of the pavement. This long design life supports sustainability. Use of perpetual pavement is a green practice that can greatly reduce emissions from asphalt plants and haul trucks during future rehabilitation and reconstruction projects. Recyclable pavement conserves nonrenewable natural resources and landfill space

### A. Design Parameters

- 1 Three distinct layers. Rut-resistant, wear-resistant surface layer, rut-resistant durable intermediate layer, and a layer of hot-mix asphalt that contributes a combination of adequate asphalt thickness and flexibility to resist deep-fatigue cracking
  - a Wear-resistant surface layer using 1.5 to 3 inches of Stone Matrix Asphalt, Open Graded Friction Course or Superpave 1/4 inch to 3/4 inch nominal maximum aggregate size for this layer. Shall be designed to resist surface-initiated distresses such as top-down cracking and rutting
  - b Durable intermediate or binder layer shall be 3 to 4 inches thick. Three-fourths inch to one inch nominal maximum aggregate size for this layer. Shall be designed to carry most of the traffic load, must be durable and resist rutting
  - c Hot-mix asphalt durable base layer that resists tensile strain caused by traffic and fatigue cracking. The base layer shall be 4 to 10 inches thick of dense graded mix made from stiff binder. Three-fourths inch to one and one-half inches nominal maximum aggregate size for this layer
- 2 The thickness of the asphalt portion section shall be greater than 8 inches
- 3 Wear-resistant surface layer must be 100 percent recyclable

- 4 Must be built on solid foundation The subgrade must have a California Bearing Ratio (CBR) greater than 5 percent (resilient modulus greater than 7,000 pounds per square inch)
- 5 High initial cost will be offset by long-term savings – lower life-cycle cost than conventional asphalt or concrete pavement.

**B Maintenance Needs**

- 1 Create a strong pavement preservation program to increase the longevity of pavement life cycle
- 2 Replace surface layer periodically

**7. RUBBERIZED ASPHALT CONCRETE (RAC)**

RAC is a road material made with recycled tires RAC is a cost-effective and environmentally friendly alternative to traditional road paving RAC generally requires less maintenance than roads with conventional AC The average life span of a RAC road before further treatment is needed (besides crack sealing) is 12 to 14 years Other benefits include quieter roadways (noise reduction up to 85 percent), better traction, and resistance to cracking Disadvantages are RAC is darker in color and absorbs more heat than the conventional pavement.

**8. WARM-MIX ASPHALT (WMA)**

WMA is not a single product, but a variety of technologies that reduce the temperature at which asphalt mix is produced and placed on the road WMA processes generally reduce the viscosity of asphalt and enable complete coating of aggregates at temperatures 35 to 100 degrees Fahrenheit lower than conventional hot-mix asphalt. Benefits include reduced fuel usage, reduced emissions, and paving benefits (usage of higher percentage of reclaimed asphalt pavement, cold-weather paving, and aids compaction)

**9. RECYCLED ASPHALT PRODUCTS (RAP)**

RAP is the term for removed and/or reprocessed pavement materials containing asphalt and aggregates The broken material is hauled to a central facility for processing RAP is processed using a series of operations including crushing, screening, conveying, and stacking When properly crushed and screened, RAP consists of high quality, well-graded aggregates coated by AC

- Design Parameters

- Hot-Mix Asphalt

Recycled hot mix is normally produced at a central RAP processing facility, which usually contains crushers, screening units, conveyors, and stackers designed to produce and stockpile a finished granular RAP product, which is then processed to the desired gradation. This product is subsequently incorporated into hot-mix asphalt paving mixtures as an aggregate substitute. Both batch plants and drum-mix plants can incorporate RAP into hot-mix asphalt.

- Cold-Mix Asphalt

The RAP processing requirements for cold-mix recycling are similar to those for recycled hot mix, except that the graded RAP product is incorporated into cold-mix asphalt pavement mixtures as an aggregate substitute.

#### Other Benefits of RAP

- Reduce the amount of virgin rocks mined for aggregate
- Decrease the energy used for processing

# CHAPTER 5: SUSTAINABLE AND GREEN PRACTICES ALTERNATIVES

## GOAL

The goals of sustainable and green practices alternatives are to reduce environmental impacts from Public Works activities and to conserve existing materials for future use

## EXPLANATION

This chapter identifies activities that do not fit into the other categories referenced in this manual, but support Public Works' goal of implementing sustainable practices in its operations. Pilot programs are recommended for detailed evaluation and refinement of these practices prior to Department-wide phased implementation.

## GREEN PRACTICES FOR CONSIDERATION

### 1. MULCH

Mulch is used for landscaping to minimize evaporation and top soil loss due to wind and runoff while reducing maintenance requirements.

#### A Design Parameters

- 1 Mulch at least 50 percent of appropriate green waste generated by Public Works' activities, e.g., tree trimming and landscape maintenance.
- 2 Create mulch storage areas at Public Works facilities wherever possible.
- 3 Ensure that sources of green waste to be mulched come from appropriate material, free from invasive plant species. Since a facility may have a mixture of invasive and noninvasive plant species, ensure that during maintenance activities trimmings of invasives and noninvasive be piled separately.
- 4 Use in all planting beds to reduce the need for pesticides and herbicides.

#### B Maintenance Needs

- 1 Mulching and storage will require space and upkeep at field facilities to prevent odors and fire hazards.
- 2 Transportation of green waste and mulch will require logistic coordination.

## **2. COMPOST**

Composting converts organic waste into a useful soil amendment, which permits the return of vital organic matter, nutrients, and beneficial bacteria to the soil.

### **A. Design Parameters**

- 1 Compost at least 50 percent of appropriate green waste generated by Public Works activities
- 2 Compost 100 percent of appropriate food waste generated from Public Works facilities.
- 3 Create composting areas at the Public Works facilities wherever feasible
- 4 Production of compost and mulch can be done simultaneously at the same location Compost can contain waste material other than green waste such as food waste, but takes longer to process.
- 5 Use as appropriate for a soil amendment, reducing the need for fertilizers, pesticides, and herbicides

### **B. Maintenance Needs**

- 1 Composting operations will require space and upkeep at field facilities to prevent odors and fire hazards.
- 2 Transportation of waste to be composed and finished product will require logistic coordination

## **3. LEADERSHIP IN ENERGY AND ENVIRONMENTAL DESIGN (LEED) STANDARDS**

LEED Green Building Rating System provides standards for environmentally sustainable construction LEED is a point-based system allowing for implementation flexibility based on site conditions and owner preference In order to demonstrate that the Department is committed to sustainable practices, Department facilities should be upgraded to LEED Silver standards as is required for other County projects The cost associated with upgrading a typical building to LEED standards varies, although most LEED retrofits tend to be large in scale However, the initial capital costs will eventually be offset by long-term energy and water savings.

## **4. SOLAR AND WIND POWER**

Solar and wind energy can be converted to electricity and interconnected with the local power utility to offset electricity use by Public Works facilities.

## Design Parameters

- Install solar panels on all feasible roof locations and install wind generators at facilities where appropriate conditions exist.
- Consider leasing space to third-party installers
- High initial costs will eventually be offset by long-term savings
- Wind generators will need concurrence from neighboring property owners, local cities, and regulators such as the U S Forest Service, U S Fish and Wildlife Service, and the California Department of Fish and Game

## 5. LANDSCAPE IRRIGATION AND MAINTENANCE

By incorporating native and drought-tolerant plants in existing and planned landscaped areas, Public Works will greatly decrease the amount of water needed for irrigation, will generate less green waste, and decrease maintenance cost.

### A. Design Parameters

- 1 Please refer to the requirements in the most current *County Drought Tolerant Landscaping Ordinance*
- 2 Replace maintenance and irrigation intensive species with drought-tolerant, low-maintenance plants
- 3 Choose plants based on specific height, width, spacing, and density needs.
- 4 Install smart irrigation controllers to reduce water demand
- 5 Utilize permeable pavement or otherwise reduce impermeable areas and increase landscaped areas if possible
- 6 For retrofit projects, replace at least 75 percent of turf grass with drought-resistant landscaping at all Public Works facilities No turf grass should be planted in newly landscaped areas.
- 7 Use leak resistant and high-water pressure (where appropriate) irrigation lines

### B. Maintenance Needs

Similar to maintenance needs of existing landscape irrigation systems.

## 6. STORE RAINWATER/RUNOFF FOR REUSE

Storage of rainwater runoff reduces the total volume of runoff and the potential pollutants entering the stormwater conveyance system. Rain barrels and cisterns are types of BMPs that may be used to store and reuse runoff. According to the County of Los Angeles Department of Public Health's (LACDPH) *Requirements for the Installation and Pipeline Construction for Safe Reuse of Rainfall/Run-off, Non-potable Cistern Water and Urban Run-off Water* (July 2009), approved use of captured rainfall is limited to subsurface irrigation. Various efforts are underway to revise these guidelines to include additional approved uses. Check with LACDPH for the most current allowed uses.

### Design Parameters

- Install above and/or below ground cisterns to collect runoff from appropriate drainage areas.
- Size cisterns consistent with drainage area and expected use.
- Ensure no interconnections with potable supplies.
- Consider drainage area with respect to pollutant loading. Should be from a relatively clean area like a rooftop or lightly used parking area.
- Use of cistern water may require pump and filter system for irrigation distribution.
- Access points must be screened for vector control.

### B Maintenance Needs

Cisterns and rain barrels should be inspected at least twice a year and repaired or replaced as needed.

## 7. GREYWATER SYSTEMS

Greywater refers to nonindustrial wastewater usually generated from domestic processes. Greywater should be applied below the soil surface where possible and not sprayed as there is a danger of inhaling the water. Benefits of a Greywater System include increased plant growth and reduced potable water demand. Most Public Works facilities have a limited amount of Greywater, thus a benefit-cost analysis should be performed prior to implementation.

## Design Parameters

- Install Greywater Systems in facilities wherever feasible
- Installation of a Greywater System is most cost-effective in new construction
- Greywater sources include nonkitchen sinks, showers, bathtubs, and washing machines
- Ensure no connections with potable supplies
- Use and distribution of Greywater may require pump system
- All irrigation using Greywater must be subsurface Care should be taken in locating the irrigation lines on properties that are on hilltops and slopes.
- For properties on hilltops or slopes, specify equipment that detects overwatering and leaking

## 8. GREEN ROOFS

Green roofs can be used in place of traditional roofs to limit impervious site area. Green roofs capture and evapotranspire 50 to 100 percent of precipitation depending on the season and help mitigate building temperature by keeping roofs cool. Roof planters can be used instead of a green roof to achieve similar results

### A. Design Parameters

- 1 Projects that have reached the end of their design life will require replacement.
- 2 Evaluate the structural capacity of the building. The structural design load must be sufficient to support the additional weight of a green roof (vegetation, waterproofing, and saturated soil/water)
- 3 Green roofs must have access for both construction and maintenance
- 4 Include drain and overflow system
- 5 Depth of soil shall vary from 6 inches (extensive) to 3 feet (intensive)
  - a. Extensive System .Depth of soil (6 to 12 inches), lighter structural load (10 to 35 lbs/ft<sup>2</sup>), requires watering during dry



season, less holding capacity of stormwater, limited vegetation opportunity because of the depth of root system, less insulation (temperature) and roof protection

- b. Intensive System Depth of soil (12 to 36 inches), heavier structural load and most likely needs additional structural retrofit (60 to 200 lbs./ft<sup>2</sup>), requires less frequent watering, holds more stormwater, greater insulation capacity and roof protection, more variety of vegetation, and shading opportunities.

6 Include waterproofing, protection boards, and a roof barrier

7 Include irrigation system for dry-weather conditions.

#### B. Maintenance Needs

1. Testing of soil/growth medium and replacement if necessary

2 General plant maintenance including pruning, removal of dead plants/branches, and replacement of dead plants if necessary (5 percent replacement)

- a. Irrigation system maintenance - specify equipment that detects overwatering and leaking.

- b. Pest/insect control – encourage biologically beneficial insects and wildlife.

### 9. RECYCLED WATER

Recycled water is domestic wastewater that is treated to standards outlined in California Code of Regulations, Title 22, that is approved by the California Department of Public Health for certain nonpotable applications. Public Works shall maximize utilization of recycled water in its construction, operations, and maintenance activities as allowed under California law

#### Design Parameters

- Spray irrigation timing must coincide with minimum potential for public contact with recycled water
- Hose bibs and quick couplers are not allowed
- All pipes must be purple or otherwise clearly indicate that they carry nonpotable recycled water

- All valves and other accessible appurtenances must be clearly marked as nonpotable recycled water
- A designated site supervisor is required for each site utilizing recycled water
- Recycled water irrigation system and recycled water use must adhere to all requirements imposed by the local recycled water purveyor and public health guidelines
- Approved Uses
  - Landscape irrigation
  - Vehicle and equipment washing.
  - Street sweeping
  - Dust control during construction
  - Water for soil compaction
  - Sewer flushing

TM cp

P:\wmpub\Secretarial\2011 Documents\Reports\Draft Stds Green Infrastructure (2).docx